



METALNA INDUSTRIJA AD
17500 VRANJE, SRBIJA
Radnička 1, Tel.: 017/421-121

INSTALLATION, USE AND MAINTAINANCE MANUAL

CFH XILA



This product meets the requirements of the Ecodesign Directive in terms of efficiency and air pollution level, in order to contribute to the reduction of energy consumption and negative environmental impact.

Introduction

We wish to thank you for purchasing ALFA PLAM product.

We prepared this short manual for you in order to make use of our product as easy as possible.

Specific technical parts of this manual should be reviewed by individuals involved in assembly, installation and commissioning of the product to ensure proper operation of the product.

- Read the instructions carefully before installation, use and maintenance of this product. This manual is an integral part of the unit. Keep it in a safe place.
- Installation, electrical connections, checking, maintenance and repairs must be carried out by qualified personnel.
- The first commissioning or operation should be carried out only by qualified personnel.
- Do not use any flammable liquids for ignition process.
- This unit must not be used by people (including children) with limited physical, sensory or mental abilities or without experience and knowledge of it, unless supervised or instructed in its use by those responsible for their safety.
- Children must be supervised at all time to make sure they do not touch hot surfaces of the unit or change settings.
- For any other information feel free to contact your distributor.

This manual uses the following symbols:



CAUTION: Safety warning



PROHIBITED: Prohibited activity



INFORMATION: Important information

ALFA PLAM a.d. declines any liability for indirect and immediate injuries or property damages caused by failure to follow or apply the instructions contained in this manual.

CAUTION

- The minimum installed power of the heating system must not be less than 65% of the nominal power of the stove and the maximum installed power of the heating system must not be more than 100% of the nominal power of the stove.
- The chimney, to which the stove is connected must meet the requirements provided in the user manual.
- When connecting the appliance to the chimney, never use flexible hoses instead of flue pipes.
- Regular maintenance and care, such as cleaning the stove, the flue pipes and the nozzles (of the pipes), are important to ensure safety, and especially for the sake of economy and in order to maintain the value of the stove.
- Unauthorized modification of the device is prohibited and therefore any unauthorized modification shall render the warranty null and void.

CONTENTS:

1.	INTRODUCTION.....	1
1.1	Product Serial number.....	1
1.2	Materials.....	1
1.3	Certificates.....	1
1.4	Dimensions.....	1
1.5	Product technical data.....	3
1.6	Fuel characteristics.....	4
1.7	General warnings and recommendations.....	5
2.1	Unit assembly.....	5
2.2	INSTRUCTIONS FOR COMBUSTION AND VENTILATION.....	6
2.3	Exhaust flue gas pipe characteristics.....	7
2.3.1.	SMOKE DISCHARGE ON EXTERNAL WALL.....	8
2.3.2.	SMOKE DISCHARGE ON ROOFWITH TRADITIONAL CHIMNEY.....	8
2.4	Unpacking and waste disposal.....	9
2.5	Electrical connection.....	9
2.6	Handling and storage.....	9
2.7	Control panel electrical connection diagram.....	10
3.	PRODUCT USE.....	10
3.1	The first ignition.....	11
3.2	Safety devices.....	12
3.3	Control panel.....	12
3.3.1.	KEYS.....	12
3.3.2.	LED.....	12
3.3.3.	DISPLAY.....	13
4.	MENU.....	14
4.1	User menu 1.....	14
4.1.1.	DISPLAYS.....	14
4.1.2.	SETTING PRODUCT POWER.....	14
4.1.3.	MANUAL PELLET LOAD.....	14
4.1.4.	PELLET FEEDER MODIFICATION.....	15
4.1.5.	COMBUSTION FAN MODIFICATION.....	15
4.1.6.	ENABLING CHRONO FUNCTION.....	15
4.1.7.	SUMMER – WINTERMODE.....	16
4.1.8.	BOILER THERMOSTATS.....	16
4.2	User menu 2.....	16
4.2.1.	THERMOSTAT MENU.....	16
4.2.2.	CHRONO MENU.....	17
4.2.3.	COMBUSTION RECIPE MENU.....	18
4.2.4.	CLOCK MENU.....	18
4.2.5.	REMOTE CONTROL MENU.....	18
4.2.6.	SYSTEM MENU.....	19
5.	MAINTENANCE.....	19
5.1	Routine maintenance.....	19
5.2	Emergency maintenance.....	20
6.	TROUBLESHOOTING.....	21
7.	CONNECTION OF THE HYDRAULIC INSTALATION.....	23
7.1	Scheme of the hydraulic installation of a pellet boiler (radiator heating).....	23
7.2	Scheme of the hydraulic installation of a pellet boiler (radiator and floor heating).....	24

1. INTRODUCTION

1.1 Product Serial number

Product Serial number can be found in the warranty and on the serial number plate affixed to the rear side of the product. In case of request for service or help Product Serial number is required.

1.2 Materials

Products of the Alfa Plam a.d. brand generally use materials which have the following advantages:

- Thick sheet-metal plates which enable the device solid structure;
- For certain models maolica or thick cast iron materials are used for unique design and elegant product processing;
- Before painting at high temperatures metal parts undergo phosphate processing in order to optimize the painting process and improve the final result;
- Gaskets, which make combustion chamber air impermeable. They must be checked periodically to prevent the improper combustion which can be a result of too worn gasket;
- Ceramic and glass elements for the combustion chamber door. For information about cleaning activities see Maintenance section.

1.3 Certificates

This product is in compliance with EN 14785 standard (residential space heating appliances fired by wood pellets). It also respects the Serbian regulations implemented in the following European directives:

- 2014/30 EU Directive (The Electromagnetic Compatibility Directive);
- 2014/35 EU Directive (The Low Voltage Directive);
- Regulation (EU) 305/2011 (Construction Products Regulation).

1.4 Dimensions

BACK SIDE

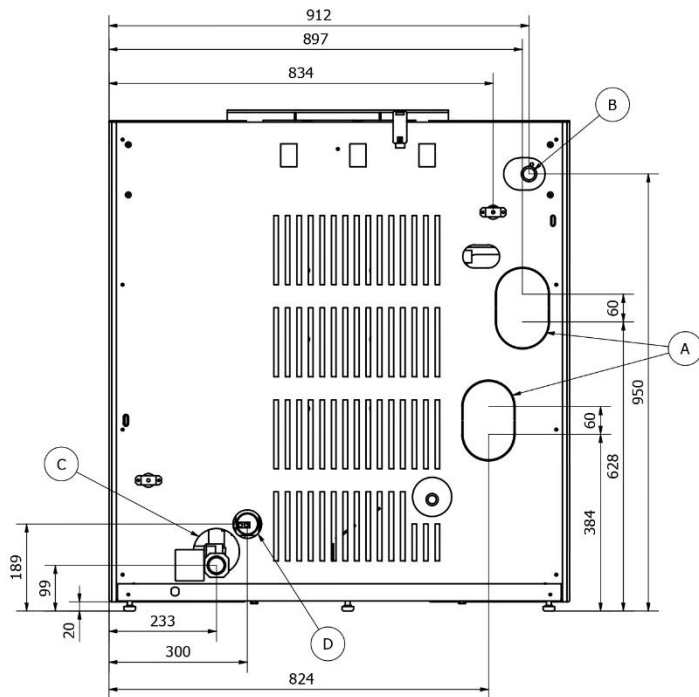

SIDE

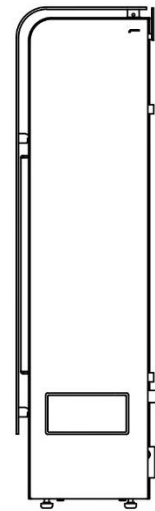

FRONT SIDE

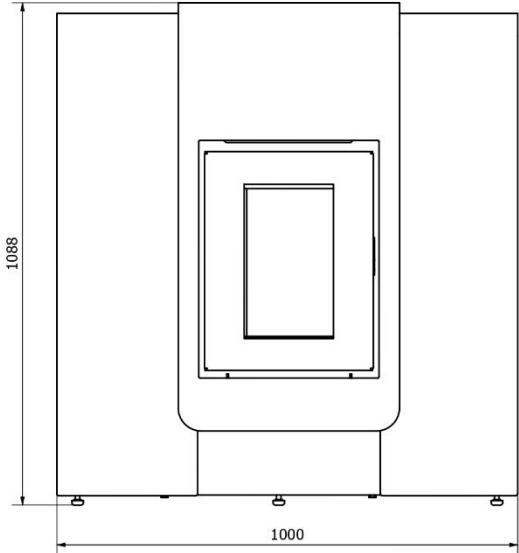

TOP

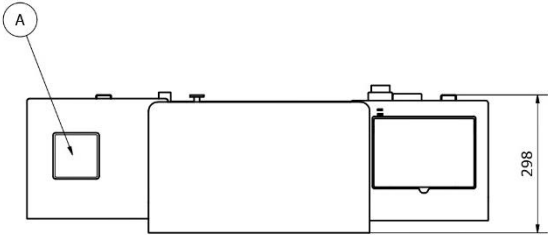

- A: Exhaust gases pipe diameter \varnothing 80
- B: 1" Unit inflow pipe
- C: 1" Unit return pipe
- D: Air intake \varnothing 50

Dimensions in mm

Details

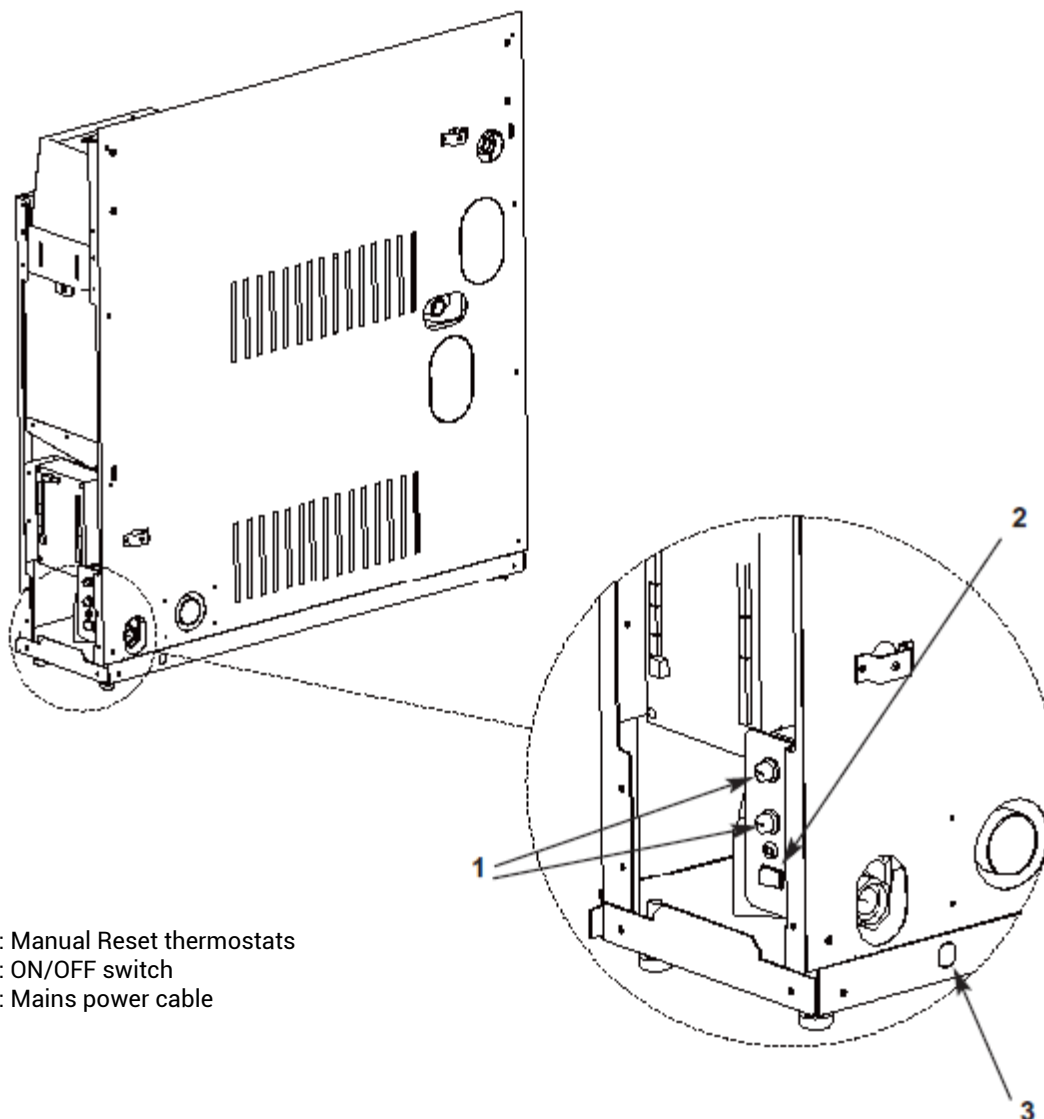

- 1: Manual Reset thermostats
- 2: ON/OFF switch
- 3: Mains power cable

1.5 Product technical data

* The values calculated in accordance with the heat demand of 35 W/m³ and a ceiling height of 3 m.

Product: CFH XILA			
	Measurement Unit	Max.	Min.
Heating power	kW	17	6
Heating power to water	kW	14,5	4,7
Heating power to ambience	kW	2.5	1,3
Efficiency	%	93.4	95.7
Emissions of CO (with 13% of oxygen)	%	0.0131	0,0074
Combustion gas temperature	°C	126	67
Gas mass flow	g/s	10,5	5,7
Minimum air flow pressure	Pa	12.0	10.0
Exhaust gases pipe diameter	mm	ø 80	
Combustion air inlet	mm	ø 50	
Water pipe diameter (inflow/return)	"	1	
Maximum operating water pressure	bar	2	
Maximum water temperature in the boiler	°C	75	
Boiler capacity	l	25	
Hopper capacity	kg	20	
Fuel	-	Wood Pellet	
Fuel hourly consumption	kg/h	3,91	1,31
Autonomy	h	5.11	15,26
Heatable volume*	m ³	570	
Rated electrical power	W	240	
Supply voltage	V	230	
Nominal frequency	Hz	50	
Net weight	kg	90	
Basic characteristics			
The controlled combustion system with flue gases heat recuperation		Standard	
Flue gases flow pressure control switch		Standard	

Self-cleaning glass	Standard
Closed vessel mounting modification	Standard
One-way control via radio	Optional
Automatic reactivation in case of power failure	Standard
Five speed mechanical ventilation	Standard
Possibility to adjust power levels (5 levels)	Standard
Weekly programming	Standard
Two-way control via radio	Optional
GSM module	Optional

* The values calculated in accordance with the heat demand of 35 W/m³ and a ceiling height of 3 m.

Results from the table were obtained using pellets certified according to the Austrian and German DIN 51731, DIN PLUS and ÖNORM M 7135 standards. Note that the CEN (European Committee for Standardization) is currently defining future European legislations which will regulate the technical specification of this fuel and the economic and environmental aspects related to this production area.

1.6 Fuel characteristics

This stove is mainly characterized by the fact that it uses natural fuel (wood pellet) which is produced in environment-friendly manner from wood industry waste (chips/sawdust). Chips and sawdust from wood processing operations are, after proper cleaning and drying, compressed under extremely high pressure to form small cylinders of pure wood: pellets. Each small cylinder may vary in size and thickness, from 1 to 3 cm in length and from 6 to 8 mm in diameter.

Wood pellet is mainly characterized by low humidity values (less than 12%) and high density (= 600 kg/m³), as well as its uniqueness and compactness which provide high calorific value of this fuel (LHV 4100–5000 kcal/kg).



Wood pellet used as fuel must have excellent qualitative characteristics, such as defined in standards DIN 51731, ÖNORM M 7135 and EN plus A1. Example of basic data is listed below.

Standard DIN plus proposes a combination of qualitative parameters proposed by the DIN 51731 standard and the Austrian ÖNORM M 7135 standard.

⚠ ATTENTION: Pellet should be produced exclusively from untreated wood sawdust without additional materials.

⊘ It is absolutely prohibited to use any liquid or solid fuels other than pellet as a stove fuel.

⚠ ATTENTION: In order to optimize the appliance functionality it is recommended to use wood pellets certified by accredited body. The use of pellets, ones not listed by the manufacturer, may result in appliance malfunction and render the warranty void. Storing and handling pellets is an important task and should be performed with care.

- Fuel must be kept in dry and warm environment.

- Handle pellet with care to avoid excessive grinding and becoming sawdust.

Compliance of these two simple rules will provide better combustion efficiency and help maintain proper functionality of moving mechanical components.

Wood pellet quality standards	Measurement Unit	ÖNORM M 7135	DIN 51731	DIN plus	EN plus A1
Diameter	mm	da 4 a 10	da 4 a 10	da 4 a 10	6 ± 1
Length	mm	5 x D ¹	< 50	5 x D ¹	3,75 < L < 40 ³
Density	Kg/dm ³	> 1,12	1,0–1,4	> 1,12	> 0,6 (app)
Water content	%	< 10	< 12	< 10	< 10
Ash content	%	< 0,50	< 1,50	< 0,50	< 0,50
Energy content	kWh/kg	> 5	4,86–5,42	> 5	> 4,5
Sculpture content	%	< 0,04	< 0,08	< 0,04	< 0,05
Nitrogen content	%	< 0,3	< 0,3	< 0,3	< 0,3
Chlorine content	%	< 0,02	< 0,03	< 0,02	< 0,02
Abrasion	% weight	< 2,3	-	< 2,3	< 1
Binding agents	% pressed mass	< 2	2	< 2	
1 At the most 20% of pellet can be larger than 7.5 times the diameter D.					
2 Standard DIN prohibits the use of any additional substances. However, this prohibition does not apply to smaller heating systems.					
3 At the most 5% of pellet can belonger than 40 mm, maximum length 45 mm.					

⚠ ATTENTION: In case the appliance will not be used for a longer period of time (more than 15 days), remove all remaining pellet from the hopper to avoid humidity increase which can lead to product malfunction.

⚠ ATTENTION: Excess humidity of pellet can cause deterioration and create dust, which can lead to increased accumulation in the boiler area and even block the pellet feed system (auger).

ⓘ When loading the hopper take care not to spill pellets in other interior parts of the product.

- ⓘ Use only pellet of 6 to 8 mm diameter.

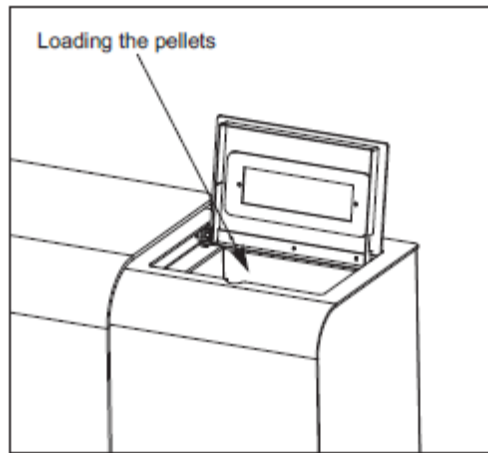

1.7 General warnings and recommendations

- ⚠ ATTENTION: Carefully read the provided manual before installation.
- ⚠ ATTENTION: The firebox must be emptied before switching on the unit and in case any problems occur when starting the unit.
- ⊘ It is absolutely prohibited to use any other solid or liquid fuel except 6 mm diameter wood pellet. Avoid the use of damp or crushed pellets.
- ⓘ In order to optimize the appliance functionality it is recommended to use wood pellets certified by an accredited body. The use of any other pellets besides those listed by the manufacturer may result in appliance malfunction and render the warranty void.
- ⊘ Do not use this unit as an incinerator or in any other way except the intended.
- ⚠ ATTENTION: If you cannot ignite the stove you have to empty the firebox. If not cleaned, it can cause an extremely strong combustion and the creation of large amounts of smoke.
- ⚠ ATTENTION: Do not open the door and do not turn off the power supply during the ignition or extinguishing phase, while the unit is operational, even if the combustion chamber is blocked or overloaded. Before dealing with the problem start the extinguishing phase and give the unit time to shut down. Do not try to reignite the unit before solving the problem.
- ⚠ ATTENTION: Do not interrupt the extinguishing process (for example, by unplugging) until it is over.
- ⚠ ATTENTION: If the wood pellet accumulates in the combustion chamber while the unit is operational, switch off the unit and switch it on with the greater ventilation program. If the pellet is still accumulating, try a different pellet or contact the manufacturer's assistance service.
- ⊘ Never load pellet into the combustion chamber manually.
- ⊘ Do not attempt any unauthorized modification of the appliance.

2. INSTALLATION

To successfully install the product and prevent the occurrence of faults you will find a number of simple tips for installation in accordance with the relevant applicable regulations. Installation, use and maintenance of the unit must comply with all local and national regulations and European standards.

2.1 Unit assembly

Our product is a heat generator which uses air required for the combustion process directly from the heated environment. For this reason and because of basic safety of the user the unit must be installed in an adequately ventilated room to ensure a continuous flow of combustion air.

Therefore, it is necessary to arrange a connection between the air intake and the external environment (as depicted in Figure 2.1).

- ⓘ Air intakes must have the following characteristics:
 1. They must have an internal cross-section of at least 80 cm²;
 2. They must be mounted close to the floor level;
 3. They must be adequately protected by wire mesh or grate so that the minimum cross-section required for air passage is not reduced;
 4. They must be placed so that they are not blocked in any way.

- ⓘ A proper flow of fresh air can be obtained through the use of an opening into the adjacent room, provided that the room is equipped with direct ventilation and there is no fire risk as in the case of storages, garages or warehouses.

It is recommended to avoid installation of the heat generator in spaces containing devices not operational when isolated from the external environment or spaces containing devices which could lower the pressure in the room because it can cause a weak air flow in our product.

- ⚠ ATTENTION: The discharge of combustion remains into a shared exhaust flue gas pipe.

When checking the compatibility of the system it is recommended to establish whether the support surface (floor) has adequate carrying capacity (kg) in order to bear the weight of the product. If that is not the case, it is recommended to take correspondent security measures (for example, use of load deployment panel).

⚠ ATTENTION: Clearance from external surfaces of the unit to any fuel or flammable materials should be: 5 cm behind, 10 cm side and 80 cm in front. If it is impossible to maintain the specified clearance, use appropriate thermal protection.

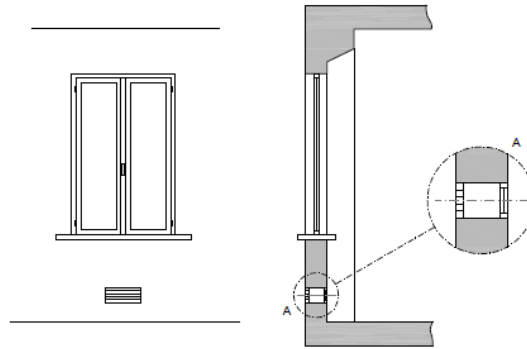

Figure 2.1: Example of required air openings

⚠ ATTENTION: Never position flammable materials near the unit or touching outer surfaces of the combustion chamber because they can reach extremely high temperatures while unit is in use.

⚠ ATTENTION: If the floor is made of flammable materials (e.g. wooden floor), it is recommended to protect it by placing a layer of non-flammable material under and around the unit.

i During the installation phase make sure that the plug can be accessed when the installation is complete.

⚠ ATTENTION: The power cord must be equipped with the appropriate connection for grounding.

⚠ ATTENTION: Avoid touching power cords with moist or wet hands.

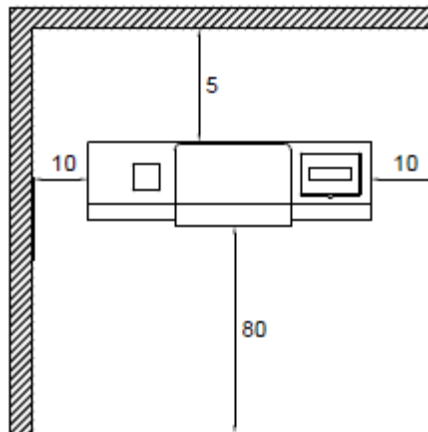

Figure 2.2: The minimum safety distance from combustible material [cm]

⚠ ATTENTION: After selection of the unit location it is possible to modify unit's height by tilting it sideways and unscrewing legs to reach the proper space from the base. To tilt the unit sideways requires two persons. After leg modification carefully lower the unit.

2.2 INSTRUCTIONS FOR COMBUSTION AND VENTILATION

Combustion air must be supplied to the rooms where the stove is installed. The room must be constantly ventilated. An fresh air opening must be located in the lower part of the room and air should enter through it.

A) Supply of combustion air by means of a pipeline through the basement. This connection option leads to a preheating of the combustion air, which is useful for a good and clean combustion. The installation of pipelines in the basement is simple.

B) Supply of combustion air through the basement. The combustion air is preheated. The basement space must be separated from the ventilation system of the house and open to the outside. High levels of dust and moisture should be avoided.

C) Supply of combustion air from above. Air supply from above can only be performed with tested chimney systems. In this case, it is necessary to calculate the dimensions of the chimney!

D) Supply of combustion air directly from outside. If combustion air is directly supplied through the outer wall, it shall be only be slightly preheated, which is unfavorable for a clean combustion. In this case there is also risk of condensation!

NOTE: We do not recommend these versions of air supply! However, if you use these options, consult a qualified professional.

In the room where the heating device is installed, it is necessary to ensure sufficient supply of fresh air. If the windows and doors are hermetically sealed or if there are air-extracting devices, such as hoods, hair dryers, fans etc., in the room where the stove is installed, combustion air (fresh air) must be supplied from outside. In any case, this should be discussed with a competent chimney sweep before installing the stove.

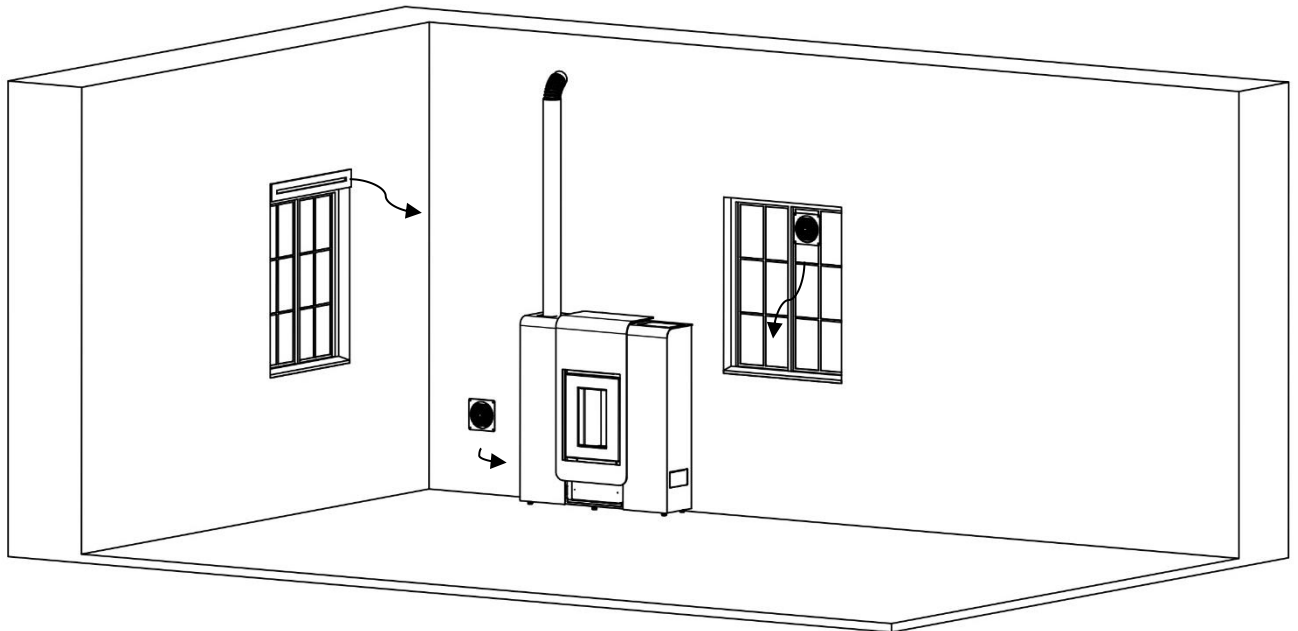

Supply of fresh air in the room where the stove is installed

2.3 Exhaust flue gas pipe characteristics

Main characteristics of exhaust flue pipe are listed below:

- Inspection valve (I);
 - Maximum height of the pipe directly connected to the unit smoke discharge must be between 2 and 3 meters;
 - If you require horizontal position do not surpass 1,5 m in length and provide a slope of 3 to 5% in order to help smoke discharge;
 - Use the rear end which is wind and water resistant to avoid slight status change of overpressure in exhaust pipe (do not interrupt the pipe with horizontal part);
- ⓘ In case of power failure the pressure in the exhaust pipe must be reduced in order to allow normal smoke discharge from the combustion chamber outside.
- ⓘ Please note that removal of all excess heat is performed by an electric control unit (modulation, extinguishing etc.).
- Exhaust gases pipes must be made of materials resistant to combustion products and condensation (check up will allow drying of accumulated condensation);
 - Pipes must be designed to prevent any possible smoke leak;
 - The exhaust pipe must be insulated, especially the outer part which is exposed to weather conditions.
- ⓘ Avoid the use of completely horizontal segments.

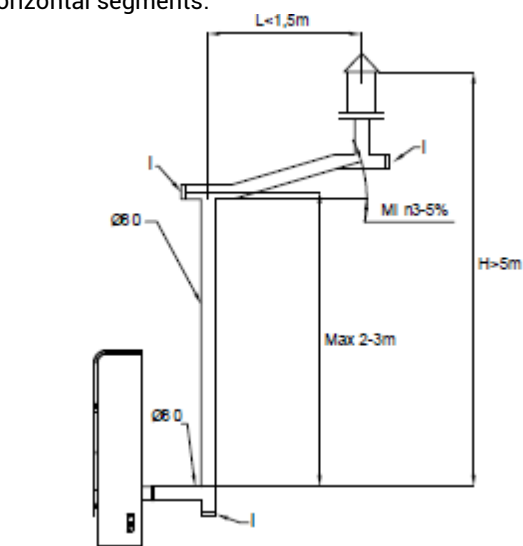

Figure 2.3: Exhaust flue pipe

- ⓘ The room where the heat generator should be installed must not have mounted aspirators because they can reduce the pressure in the environment.
- ⓘ It is strictly prohibited to close the air intakes.
- ⓘ The exhaust pipe should be cleaned at least once a year; we recommend performing a thorough cleaning of the pipe and its connections.
- ⓘ After longer period of inactivity and before start up check for blockages.

⚠ ATTENTION: The smoke discharge must be executed in accordance with the provisions of the applicable regulations.



ATTENTION: Check with appropriate tool if the minimum pressure of 12 Pa is in the chimney.

2.3.1. SMOKE DISCHARGE ON EXTERNAL WALL

One of the possible solutions is to position the pellet unit near the external wall of the house and discharge exhaust gases directly outside (Figure 2.4). Below you can find certain number of indications that point out the standard for this type of system configuration

- Always make sure there is an inspection opening (I) which will enable regular cleaning activities and removal of possible accumulated condensation;
- 'T'coupling must be wind and water resistant;
- Make sure the discharge pipe is properly insulated in the section that passes through the wall.

If the discharge pipe is completely outside, it must be made of stainless steel with double sides in order to provide better resistance to atmospheric conditions as well as the proper temperature of exhaust gases.

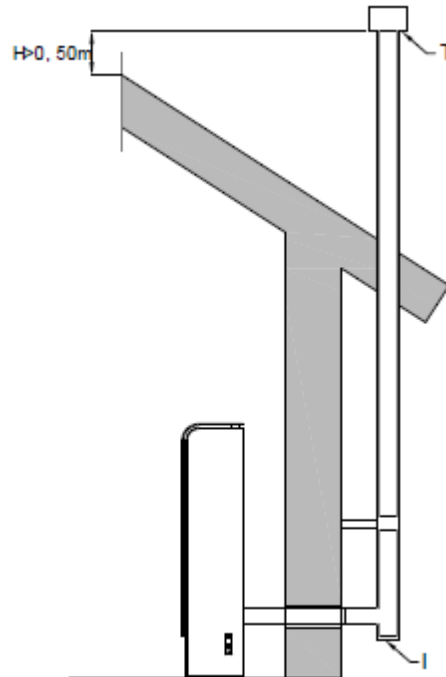

Figure2.4.: Smoke discharge on an external wall

2.3.2. SMOKE DISCHARGE ON ROOF WITH TRADITIONAL CHIMNEY

Combustion smoke can be also discharged by already existing traditional chimney (Figure 2.5), provided it complies with applicable standards. Main characteristics of a good chimney (C) are listed below:

- Proper insulation, especially of the outer part which is exposed to weather conditions;
- Constant internal diameter (smaller diameter parts should not be used);
- It must be made of a material resistant to high temperatures, combustion product effects and corrosive effects of possible condensation;
- Predominantly vertical configuration without discrepancy on vertical angle larger than 45°.

It is recommended that the base of the chimney is equipped with a collection chamber for solid materials or condensation (R). This chamber must be equipped with the hermetic door (I).

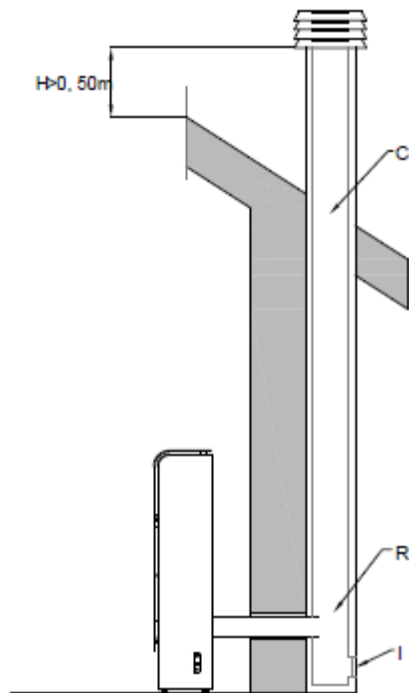

Figure 2.5: smoke discharge with traditional chimney

It is recommended not to use exhaust pipes with internal diameter smaller than 100 mm.

In case the exhaust pipes have larger diameter, a steel pipe (A) must be inserted in the brick or concrete chimney (C), as depicted in Figure 2.6.

ⓘ The steel pipe must be insulated by adequate material resistant to heat, such as stone wool or vermiculite (B), and it must be separated from the outer part of the chimney.

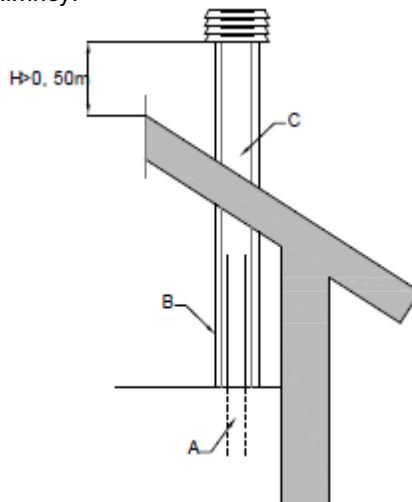

Figure 2.6: Example connection to the chimney

ⓘ In case of fire in the chimney or exhaust pipe immediately switch off the unit and disconnect it from the power supply

2.4 Unpacking and waste disposal

The packaging consists of non-toxic and non-hazardous materials. No special requirements needed for disposal. Disposal of the remaining packaging is the responsibility of the user who must carry out the appropriate procedures for disposal in accordance with applicable standards of the country in which the product is installed.

⚠ ATTENTION: Packing material must be kept out of reach for children without supervision or individuals with disabilities.

2.5 Electrical connection

The electrical connection to the network must be performed after the hydraulic connection.

ⓘ Connect the product to household powerline.

ⓘ Press the ON/OFF button, at the rear end of the unit, if you wish to turn the unit on. This way the unit is ready for ignition. For further information see section 3.1.

2.6 Handling and storage

ⓘ The product must be handled in an upright position using a forklift or other suitable transport vehicle.

ⓘ Protect glass, plates, door and other sensitive components of the product from shocks and vibration.

- ⓘ Make sure the ash bins are properly positioned during product operation.
- ⊘ Any unauthorized modification of the product is prohibited.
- ⓘ Use only spare parts recommended by the manufacturer.

3.1 The first ignition

Pay special attention to the cleaning of the firebox before starting the ignition phase and make sure that the plate below the firebox is properly FASTENED.

The proper function of the device is possible when there is no uncontrolled air intake, so the door HAS TO be tightly closed and all other routes should be sealed except the one predicted. It is recommended to check if the door seal is well compressed along the door closure line.

The EN14785 regulation for installation of the product on pellets prescribes necessary vacuum of 10 Pa at the base of the exhaust flue pipe and for this reason special attention has to be paid to the smoke discharge system. The lower and more winding exhaust pipe causes air flow required for combustion (which can change and influence the combustion itself) to be also lower. Slow exhaust gas flow, in some cases, can provoke temperature increase which creates the modulation of the operation power.

Since there are different types of pellets on the market the product operation has to be adjusted to the certain type of fuel to be used.

In order to provide customers a chance to adjust their stove to different types of pellets and different types of installation the User menu contains four recipes, ascending from 1 to 4. By increasing the recipe identification code the system ventilation is increasing too. If in the end, none of the recipes produces efficient combustion, bear in mind that the operative parameters can be changed ONLY with the help of specialized technicians from the Alfa Plam Company, who will analyze the situation and offer the best solution.

ⓘ In order to properly heat the system it is recommended to adjust the product power to values 4 or 5 during ignition phase and a few minutes after.

As an additional user assistance, below you can find the order of steps needed to turn on the product:

- 1) Make sure the system is properly filled with water;
- 2) Fill the hopper with the appropriate amount of fuel. We recommend not to fill the hopper to the maximum, optimal level is reached by loading fuel until it reaches the panel with circular holes inside the hopper;
- 3) Plug in the product to the power supply;
- 4) Press the switch at the rear side of the stove;
- 5) Fill in the auger by pressing and holding the key *Manual pellet input* (Menu) in order to activate the manual load procedure by activating the continuous mode of the auger motor. The lower display shows **Load**, while the upper shows the elapsed input time. In order to interrupt the load, press the button. Loading is automatically interrupted after 300 seconds.

⚠ ATTENTION: The system has to be in OFF operation mode to perform this operation.

⚠ ATTENTION: It is necessary to repeat the loading of the auger every time the hopper is empty.

6) Empty the firebox;

7) In order to switch on the stove, hold ignition key for a few seconds. The stove will initiate the check up and ignition phase, completely independently, the way the system demands it. During check up errors might appear that will prevent the stove to ignite.

⚠ ATTENTION: If the ignition process fails, repeat the operation in order to empty the firebox. Neglecting this repetition leads to higher risk of over combustion which ejects too much smoke into the environment.

⚠ ATTENTION: DO NOT, under any circumstances, put your hand into the auger to load pellet while the boiler is active.

⚠ ATTENTION: Do not open the door or plug the device out of power supply, even when there is a blockage or fuel accumulation in the firebox. Start the extinguishing process and resolve the problem before new ignition procedure.

⚠ ATTENTION: The stove can operate only when the heating installation is connected and filled with water. Use of the device without fulfilling these conditions may damage the product severely. In such case the warranty is void.

⚠ ATTENTION: The heating installation must be filled with water and under pressure of at least 1.2 bars when the temperatures are low. Also check for air bubbles that can enter the pump and provoke a blockage. For proper function of the device and heating it is necessary to eject the air out of the heating installation. **This activity must be regularly performed by authorized and trained personnel.**

PRODUCT EXTINGUISHING

Press and hold the **Ignition** key for few seconds. The stove will start the extinguishing process as predicted in the plan phase (the time of extinguishing may vary and it could take up to few minutes).

⚠ ATTENTION: We do not recommend the extinguishing process interruption before it is finished, for example, by plugging out the power cord.

ⓘ If the flame is out due to pellet deficit, turn off the stove. When the stove is extinguished add more fuel in the hopper in order to start a new ignition process.

⊘ DO NOT load pellet into firebox by hand.

⚠ ATTENTION: While the device is operating, the door must be closed. It is allowed to open them only for maintenance when the product is cold.

ⓘ It is forbidden to make any changes on the device.

ⓘ Self-initiative reconstruction of the product, use of non original spare parts, or unauthorized change of product parts and warranty annulment can lead to failures and severely endanger the safety of those directly operating the device.

⚠ ATTENTION: While using the device, avoid blocking the ventilation holes that enable the continuous combustion air flow and air vents on the backside of the product.

3.2 Safety devices

The product is equipped with the following safety devices:

- Probe for measuring smoke temperature: this component allows you to read flue gas temperature and constant monitoring of the product operation;
- Thermostat with manual controls for detection of excessive water temperature in the boiler. If it is reached, the product must be unblocked by pressing the safety button located at the rear side of the product;
- Manual thermostat reset for measuring the hopper temperature blocks the product operation if certain safety limit is exceeded;
- The pressure switch allows detection of all potential obstructions in the flue gas pipe;
- safety valve with 3 bars calibration;
- Water pressure sensor;
- Air intake meter.

⊘ It is prohibited not to install or remove any of the safety devices described above. Devices which are temporary disabled or shut down for maintenance must be mounted before the product use.

Activation of one of these devices leads to error message on display.

Possible error messages that can occur are listed in the relevant table.

ⓘ Safety intervention of the pressure switch and pellet thermostat is detected and regulated by the control unit only if the boiler is operating in all phases except when the device is switched off or blocked.

ⓘ Pressure switch and pellet thermostat errors are electrically placed in series so that the appearance of one of these inconveniences automatically switches the stove off and the next block of activities.

ⓘ It is possible for one or more sensors to be interrupted or short circuited. This will be detected during the check up phase. The failure of these probes could lead to ignition failure, continued state of modulation of the stove or temperature changes in the environment over time. After occurrence of such events contact authorized personnel.

3.3 Control panel

Control panel functions can be controlled via control panel with 8 keys. Below the control panel are shown keys and further below are described LEDs and different display messages.

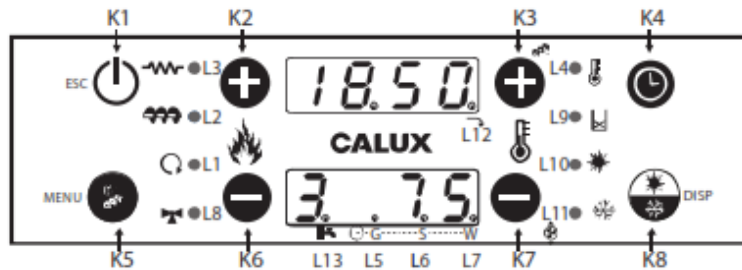









3.3.1. KEYS

Each key is used for one or more functions as shown in the table below:

KEY	CLICK	HOLD
K1	Exit Menu	Lock function ON/OFF/Reset
K5	User menu 2 input/Save changes	Manual pellet load
K2 K6	Combustion power modification (+)	-
	Combustion power modification (-)	-
K3 K7	Boiler thermostat modification (+) / Increase parameter	Reset pellet load
	Boiler thermostat modification (-) / Decrease parameter	Reset smoke ventilation
K4	-	Enable Chronotime zones
K8	Display	Summer/Winter mode

3.3.2. LED

LED	DESCRIPTION
L1	LED ON: Pump is active
L2	LED ON: The auger is in ON interval

	L3	LED ON: Heater switched on			
	L4	LED ON: Thermostat temperature achieved			
 <table border="1" style="display: inline-table; vertical-align: middle;"> <tr><td>G</td></tr> <tr><td>S</td></tr> <tr><td>W</td></tr> </table>	G	S	W	L5	LED ON: Daily programming
	G				
	S				
W					
L6	LED ON: Weekly programming				
L7	LED ON: Weekend				
	L8	LED ON: Valve is active			
	L9	LED ON: No pellets in hopper			
	L10	LED ON: Summer mode selected			
	L11	LED ON: Winter mode selected			
	L12	LED ON: Pellet safety valve or Pellet feeder motor or Cleaning motor is active (only for V2 out)			
	L13	LED ON: Request for running water (closed contact). Only for hydraulic systems which have available use of <i>Flow Switch</i> .			

3.3.3. DISPLAY

Below are depicted three types of displays, respectively:

1) Upper display

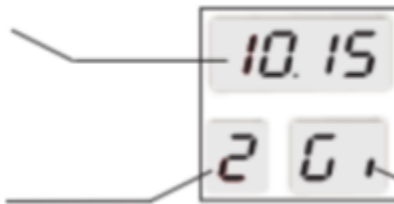

2) Lower left display

3) Lower right display

- Variables displayed on the main screen:
- Upper display: time, operation mode, error, menu, sub-menu, values
- Lower left display: power, parameter code
- Lower right display: main temperature, parameter code
- Indicated operation status:
- Check Up (CHEc)
- Ignition (On 1, On 2, On 3, On 4)
- Stabilization (On 5)
- Modulation (Mod)
- Stand By (StBY)
- Normal
- Safety (SAF/Erxx)
- Extinguishing (OFF)
- RecoverIgnition (rEc)
- Block (Alt/Erxx)
- Errors (Alarms)

DISPLAY	DESCRIPTION
Er01	Safety thermostat activated
Er02	Safety manometer activated
Er03	Extinguishing due to low temperature of flue gases
Er04	Extinguishing due to high water temperature in the boiler
Er05	Extinguishing due to high temperature of flue gases
Er07	Encoder error. No signal
Er08	Encoder error. Unable to adjust number of revolutions
Er09	Low water pressure
Er10	High water pressure
Er11	Error due to problems with the internal clock
Er12	Extinguishing due to ignition failure
Er15	Power outage longer than 50 minutes
Er17	Airflow regulator error
Er39	Airflow regulator error
Er41	Minimum airflow in CHECK UP phase not reached
Er42	Maximum airflow exceeded

- Other messages

Display	Description
Sond	Display status of temperature probes. The message is displayed during the check up phase and indicates that the temperature which is read on one or more probes is equal to the minimum value (0°C) or maximum value (depending on the probe in question). Check that probes are not open (0°C) or a short circuit occurred (reading the maximum value on temperature scale).
Hi	Water temperature in the boiler exceeds 99°C.

FLu	The message is displayed during normal phase and indicates there is a request for running water. Only for hydraulic systems which have available use of <i>Flow Switch</i> .
OFF dEL	The message that appears if the system is not switched off manually during ignition (after Preload): the system stops only when it reaches the speed.

4. MENU

Control panel menu consists of a user menu that allows end users to operate the stove regarding their needs and a secret menu that allows authorized personnel to modify operation parameters, perform operation tests of outputs and check operation history of the system.

4.1 User menu 1

User menu 1 consists of sub-menus for quick access and displays where you can see and modify some parameters.

4.1.1. DISPLAYS

This is a display sub-menu showing values of some parameters.

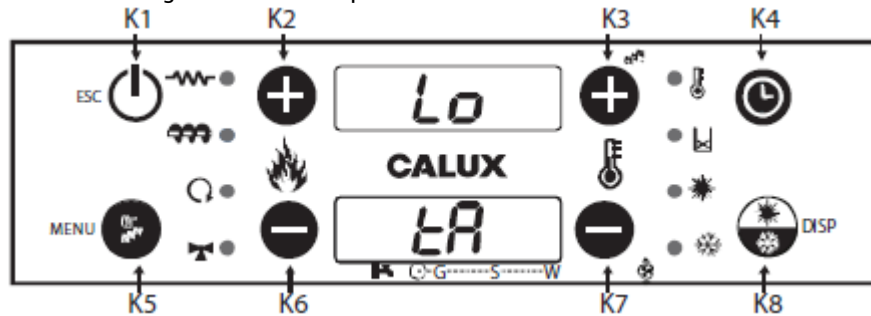

Click **K8** key to open **Display** sub-menu.

If you continue to press **K8** key, lower display shows specific parameter while upper shows specific parameter value. Possible displays are listed in the table.

DISPLAY	PARAMETER
tA	Room temperature
tP	Pump temperature (visible only if thermostat exists)
tF	Smoke temperature
UF	Oxidation fan speed [RPM/Volt]
FUnC	Summer(ESt)/Winter(InU) mode
FC	Firmware code and revision: FYSD01000114.00.00 (product without two-way radio) FYSD01000102.00.00 (product with two-way radio)
395	Manufacturer production code: 0Y.OX

N.B: If the value of the displayed parameter consists of a large number of characters continue to press **K8** key to see the entire value.

4.1.2. SETTING PRODUCT POWER

This sub-menu allows the power change of the device

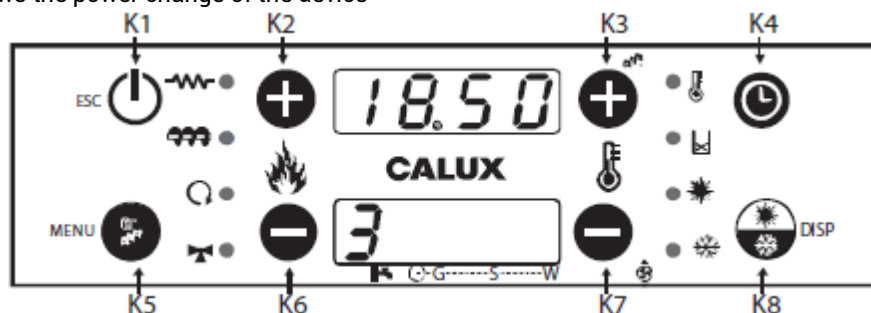

Click **K2/K6** key: lower left display blinks.

Successive clicks can change the power according to available values. For example: 1-2-3-4-5-A (A = Automatic combustion). After 3 seconds the value is stored and the display returns to normal.

4.1.3. MANUAL PELLET LOAD

This sub-menu allows activation of manual pellet load process.

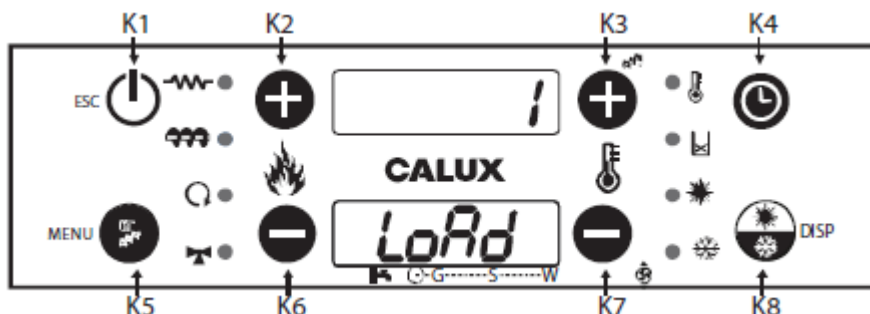

Press and hold **K5** key, manual load procedure is activated with continuous activation of the auger motor. The lower display shows **LoAd** and upper shows elapsed load time. To stop loading press any key. Loading is automatically stopped after 300 seconds.

4.1.4. PELLET FEEDER MODIFICATION

This sub-menu allows pellet feeder modification.

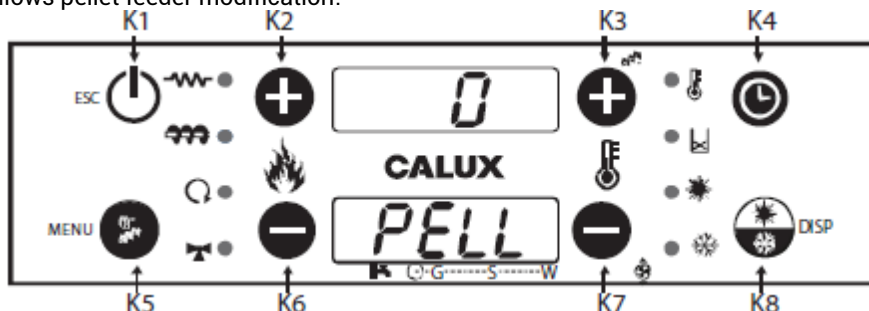

To access the sub-menu press and hold **K3** key. The lower display shows **Pell** and upper display shows set value. **K3/K7** keys increase/decrease these values; default value is '0'. After 3 seconds value is stored and the display returns to normal. This function allows you to make small corrections in the amount of pellet introduced during operation.

4.1.5. COMBUSTION FAN MODIFICATION

This menu allows modification of combustion fan.

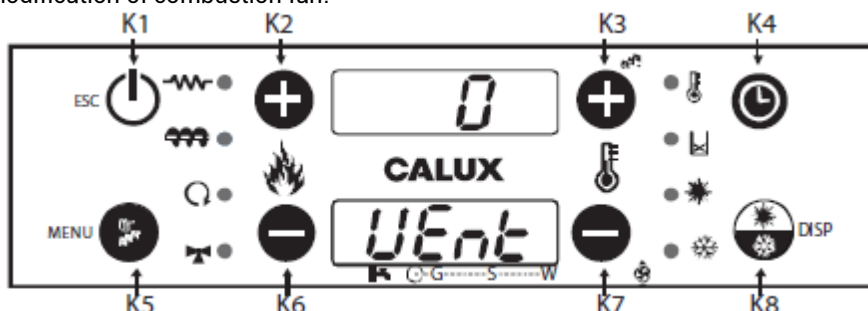

Press and hold **K7** key to access the sub-menu. The lower display shows **UEnt** and upper display shows set value. **K3/K7** keys increase/decrease these values; default value is '0'. After 3 seconds value is stored and the display returns to normal.

4.1.6. ENABLING CHRONO FUNCTION

This sub-menu allows activation/deactivation of chrono programming mode.

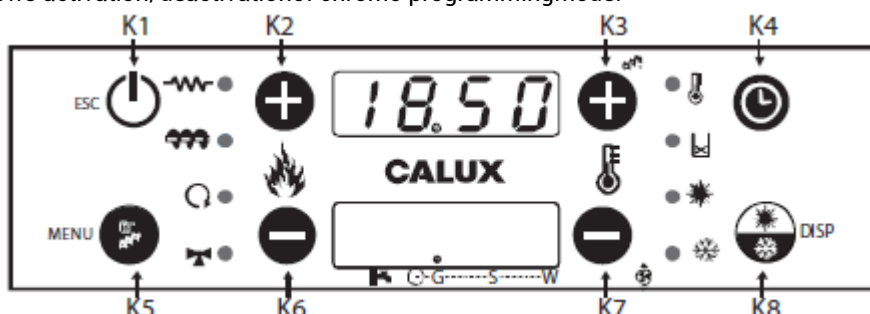

Press and hold **K4** key to choose and enable mode.

In the lower display, during each activation/deactivation, the LED light corresponding to a specific chrono mode will turn ON/OFF, see the following table.

Daily program	● ○ ○
Weekly program	⌚-G—S—W
Weekend progra	○ ● ○
Chrono function disabled	⌚-G—S—W
	○ ○ ●
	⌚-G—S—W
	○ ○ ○
	⌚-G—S—W

4.1.7. SUMMER – WINTERMODE

This sub-menu allows modification of the system mode.

Press and hold K8 key to change the system operation mode by turning on the LED light for summer mode or winter mode.

4.1.8. BOILER THERMOSTATS

This sub-menu allows you to see and modify temperature value of the boiler thermostat.

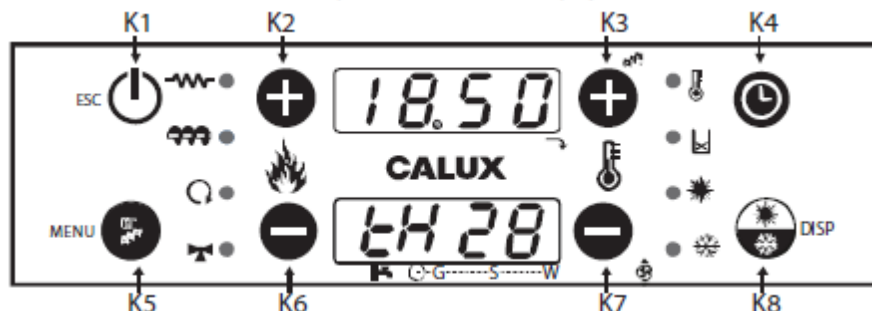

K3/K7 keys increase/decrease these temperature values. The lower display shows tH and the blinking set value the boiler should reach.

4.2 User menu 2

User menu 2 consists of additional menus where you can see and modify some parameters.

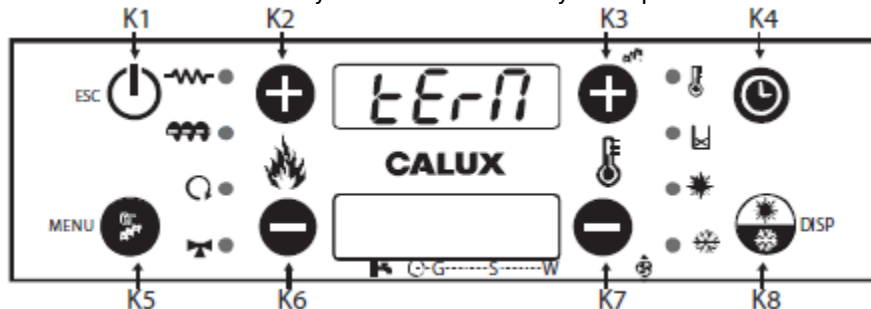

Press K5 key to access the User menu 2.

Use keys K3/K7 to scroll through menu options shown on display. See table below:

DISPLAY		DESCRIPTION
t E r M		Menu allows modification of room thermostat and pump thermostat values
C r o n	P r o G	Menu for programming of time periods ON/OFF for stove with 3 modes
r i c E		Combustion recipe menu
o r o L		Clock modification menu
t E L E		SYTX remote control activation/deactivation menu
t P A r		Secret menu access menu (exclusively for the technical assistance network)
LEAr		Remote control code learning menu. Only if the product has two-way radio option.

User menu 2 settings are shown in the upper display.

Press K1 key to exit User menu 2.

4.2.1. THERMOSTAT MENU

Thermostat menu allows you to modify the value of the main system thermostat.

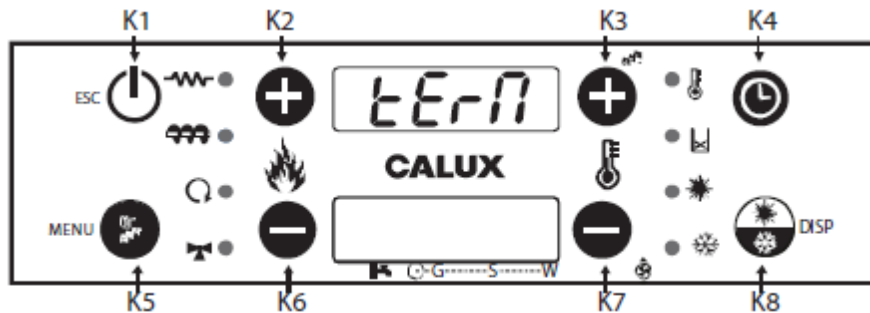

The upper display shows **tErM**. Click **K5** key to access the menu. The following settings are available in **Thermostat menu**:

Display	Thermostat	Description
AMb	Room	Menu allows modification of the room thermostat value
PuFF	Pump	Menu allows modification of the pump thermostat value; (visible only if pump probe mounted)

To modify parameter click **K5** key; the upper display blinks.

K3/K7 keys increase/decrease this value. To store the setting click **K5** key or **K1** key to exit. To return to **User menu 2** settings press **K1** key.

4.2.2. CHRONO MENU

Chrono menu allows programming of the automatic system start up or shut down.

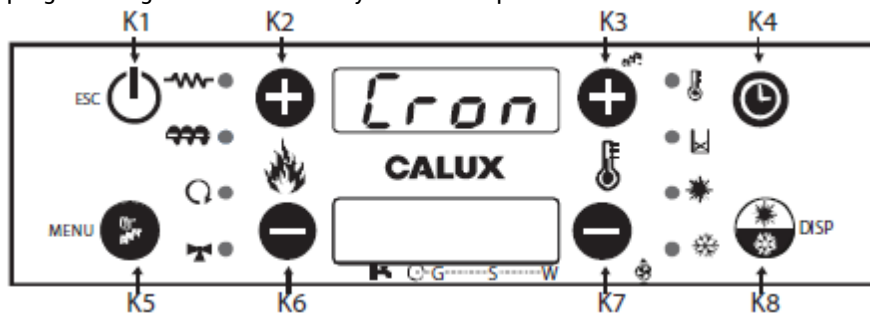

The upper display shows **Cron**. Click **K5** key to access the menu.

When you access the menu, the upper display shows **ProG**, and this menu has 3 sub-menus for 3 available programming modes:

- **Daily**: allows you to set 3 programs for each day of the week;
- **Weekly**: allows you to set 3 programs a day, equally for all week days;
- **Weekend**: allows you to set 3 programs a day, with Monday to Friday program and Saturday-Sunday program.

DISPLAYS	DISPLAY
Daily mode: day of the week	Mo
Weekly mode: Monday – Sunday	MS
Week End mode: Monday – Friday	MF
Saturday – Sunday	SS
For hours during which the stove is TURNED ON, segment at the bottom of the lower left display is on.	1i ---- Mo
For hours during which the stove is TURNED OFF, segment at the top of the lower left display is on.	---- 1l Mo

Instructions

Each program must have the set time of TURNING ON and TURNING OFF.

DESCRIPTION	DISPLAY
1) Use K3/K7 keys to scroll until you reach wanted sub-menu and press K5 key.	Gio r n
2) Press K3/K7 keys to select one of three possible programming options.	1i ---- Mo
3) Press and hold K4 key for 3 seconds.	00.00
4) Choose the start up time.	
5) Press K5 key to open change section: selected value (hours or minutes) blinks. Press K5 key to switch between hours and minutes, K3/K7 to modify values.	0 1. 0 0 1i Mo
6) Press K5 key to store the set value.	2 1. 3 0 1i Mo
7) Using K3 key select the time of SHUT DOWN and repeat procedures from step 5.	00.00 1l Mo

For each programming minutes can be set as follows: 20:00; 20:15; 20:30; 20:45).

Only if you set value 23 for hours you can increase value of minutes from 45 to 59 in order to gain midnight start up.

Midnight programming

Set the SHUT DOWN time to 23.59 for the day of the week. Set the STRAT UP time to 00.00 for the day of the week.

Example:

Monday chrono programming				
ON	22.00	Mo	23.59	Mo
	1		1	
Tuesday chrono programming				
ON	00.00	Tu	07.00	Tu
	1		1	

4.2.3. COMBUSTION RECIPE MENU

Combustion recipe menu allows combustion recipe modification.

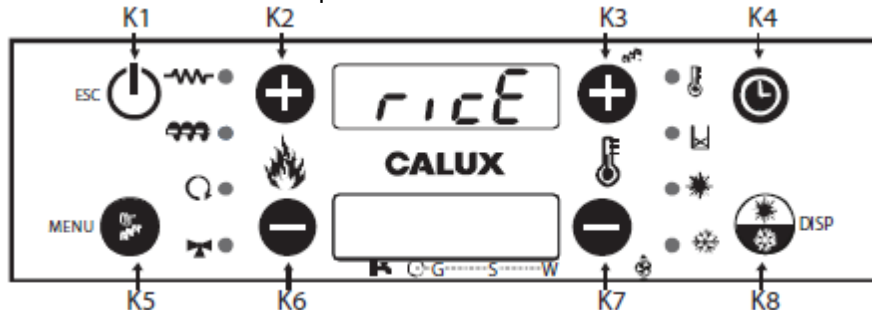

The upper display shows **rice**. Click **K5** key to access the menu.

When you access the menu the upper display shows current recipe.

To modify the recipe click **K5** key; the upper display blinks.

K3/K7 keys increase/decrease these values. To store the setting click **K5** key or **K1** key to exit. To return to **User menu 2** settings press **K1** key.

4.2.4. CLOCK MENU

Clock menu allows modification of current date and time.

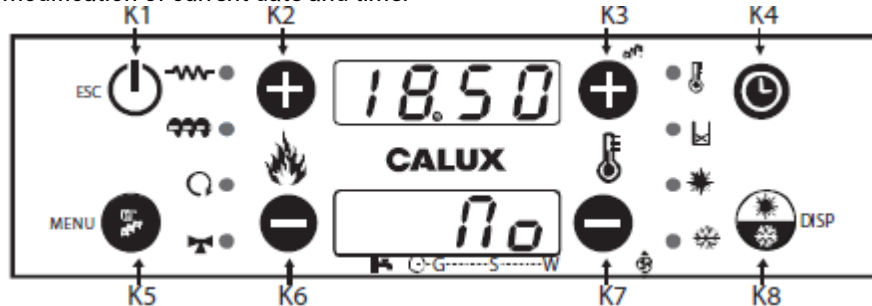

The upper display shows **18.50**. Click **K5** key to access the menu.

The upper display shows hours and minutes. The lower display shows the day of the week.

CLOCK PROGRAMMING PROCEDURE	
Instructions	Display
Press K5 to access changes. Set value (hours, minutes, day) blinks. Modify value using K3/K7 keys.	07. 33 Mo
Press K5 key to switch to parameter changes.	
Again press K5 to store the set value.	

To return to **User menu 2** settings press **K1** key.

NOTE: Proper change of this function is critical for function of automatic start up and the stove operation.

4.2.5. REMOTE CONTROL MENU

Remote control menu allows activation/deactivation of remote control.

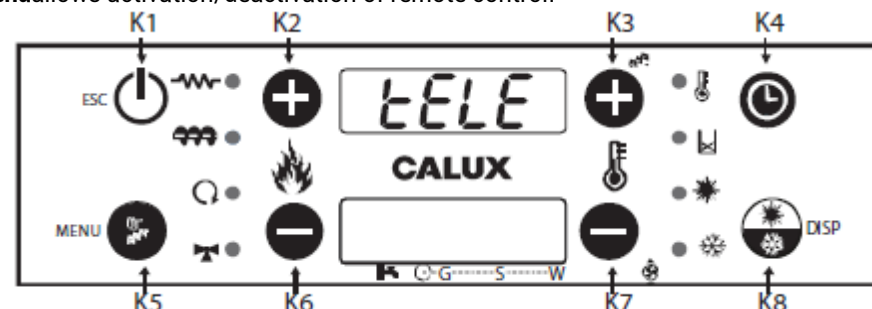

The upper display shows **ELE**. Click **K5** key to access the menu.

To modify parameter click **K5** key; the upper display blinks.

K3/K7 keys modify the value from SWITCHED OFF to SWITCHED ON (or vice versa).

To store the setting click **K5** key or **K1** key to exit. To return to **User menu 2** settings press **K1** key.

4.2.6. SYSTEM MENU

This menu allows access to **System menu**. The upper display shows **PAR**.

⚠ **ATTENTION:** This menu cannot be accessed because it is only for the technical assistance network.

5. MAINTENANCE

5.1 Routine maintenance

The stove has to be maintained periodically in order to secure its proper and efficient functioning.

ⓘ Routine maintenance is performed by the customer.

ⓘ To ensure durability and proper function, the device is designed with less moving parts which could, in time, cause uncontrolled air intake and thus endanger the combustion quality.

⚠ **ATTENTION:** Cleaning activities described below must be performed only when the stove is completely cold and disconnected from the power supply.

⚠ **ATTENTION:** The stove can be disconnected from the power supply in two ways: switching off the rear side power key or pulling out the power cord from the socket (either the wall socket or stove rear side connection plug).

The combustion chamber (marked A in Figure 6.1) is automatically cleaned during the extinguishing phase in order to secure the prescribed air flow into the combustion chamber. If there is any pellet left in the combustion chamber, remove it manually by brush or vacuum cleaner.

⚠ **ATTENTION:** The cleaning of side areas of the combustion chamber with a vacuum cleaner before activation is recommended.

⊘ Do not make any modifications on the combustion chamber.

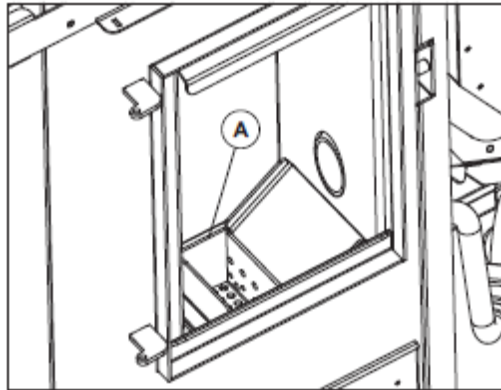

Figure 6.1: Combustion chamber

In order to remove the combustion remains, the product is equipped with the mobile panel (marked A in Figure 6.2). For detailed cleaning remove the ash compartment panel by unscrewing the fixing bolts and continue vacuuming the ash.

When re-assembling, make sure the panel is firmly sealed.

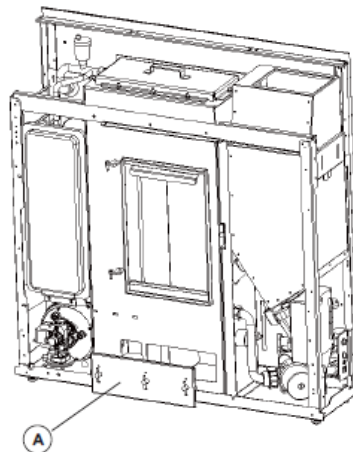

Figure 6.2: Opening ash compartments

⚠ **ATTENTION:** After maintenance, firmly seal the plate. Any air inflow due to improper assembly could result in poor combustion which leads to product malfunction.

The ash compartment below the combustion chamber must be cleaned before every ignition. On the other hand, the lower ash compartment which can be accessed from the side of the combustion chamber does not have to be vacuumed that often.

⚠ **ATTENTION:** Cleaning activities must be performed when the stove is completely cool.

⚠ **ATTENTION:** Remove the power cord from the power supply.

ⓘ It is recommended to clean above mentioned areas by included brush or vacuum cleaner.

The glass has to be cleaned more often due to inevitable combustion remains that will accumulate on it. The frequency of this occurrence depends on the type and quantity of the fuel used.

ⓘ Clean the glass only when it is completely cold using nonabrasive cleaners.



After heating period it is recommended to remove the remaining pellet from the hopper and store it according to instructions in the first chapter.

ⓘ The exhaust gas pipe and its components should be cleaned in detail (at least once during the season) to prevent the risk of fire.

Combustion chamber gaskets should be checked for consumption tear because it can result in poor combustion process. Open the door and check integrity of combustion chamber gaskets.



5.2 Emergency maintenance

This chapter is specifically intended for technicians and specialized personnel called to intervene on our product and offer useful instruction for operations necessary in order to maintain the perfect condition of the device.

ⓘ Thorough and precise maintenance of the equipment is recommended every season.

⚠ATTENTION: Special maintenance operations on the system must be performed by qualified personnel while the stove is cold and disconnected from power supply.

⚠ATTENTION: The stove can be disconnected from the power supply in two ways: switching off the rear side power key or pulling out the power cord from the socket (either the wall socket or stove rear side connection plug).

In case the maintenance operations described in previous chapters turn out to be insufficient (unusual device functioning, low yield, fuel over - combustion etc.) and every two years, no matter what, a technician must be called to perform the detailed cleaning of components in direct contact with thermal vector fluids.

The product is equipped with the upper access for pipe cleaning performed 1–2 times per season. The frequency may vary depending on conditions of use.

To use the access remove the stove cover.

After removing the cover, loosen the fixing bolts in order to access the pipe cover (see part marked A in Figure 6.3).

Now you can continue with cleaning using a brush or a vacuum cleaner.

Steel fan of the smoke discharge unit and its base must be cleaned at least once every two years.

The smoke discharge unit (marked A in Figure 6.4) can be accessed by removing the stove cover and loosening the fixing bolts.

Once accessed, the fan can be removed by loosening three bolts holding it to this unit.

N.B: Cleaning can be easily performed by vacuum cleaner.

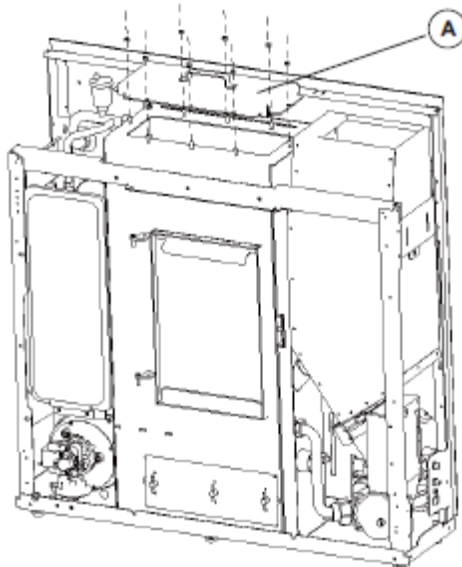

Figure 6.3: Access to pipes

i When returning the cover it is recommended to seal them using high temperature resistant silicone, for example, to ensure they are air-tight.

i It is recommended to contact manufacturer support center to get additional information and advice on products that should be purchased.

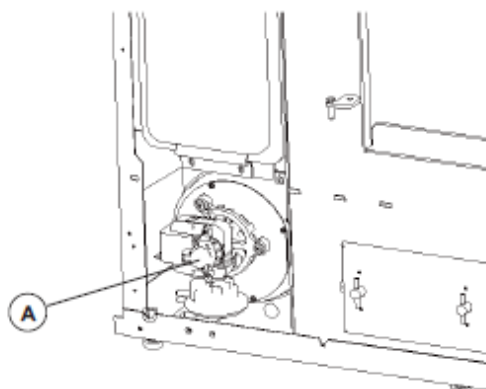

Figure 6.4: Smoke discharge unit

6. TROUBLESHOOTING

This chapter should help our customers to quickly understand any problem that might occur during use of the stove. If these solutions do not help resolve the problems you may encounter, contact service for additional information.

DISPLAY MESSAGE	DESCRIPTION	POSSIBLE CAUSES	RESETTING ERRORS	POSSIBLE SOLUTIONS
Er01	Safety thermostat activation	High water temperature in the boiler	Allow the machine to shut down and reset timers by unscrewing two spark plugs at the back of the unit and pressing both buttons	Check air intake opening for blockages
		Too high environment temperature (insufficient temperature reduction in the boiler)		
		Faulty probe		Contact service

Er02	Safety manometer activation	Flue gas pipe is blocked	Press and hold ON key for 3 seconds	Check soiling of the flue gas pipe and its components
		Incorrect installation of the flue gas pipe		See chapter 2 <i>Installation, use and maintenance</i> of the manual
		Faulty probe		Contact service
Er03	Shut down due to low flue gas temperature	Poor combustion (too much or too little of pellet remains in the combustion chamber)	Allow the machine to shut down and then press and hold ON key for 3 seconds	Check the suitability of pellet
		NO pellet in the hopper		Check soiling of the combustion chamber
		Faulty flue gas pipe probe		Check flue gas pipe connections
Er04	Shut down due to overheated water	Inadequate waste of heat produced by the boiler	Allow the machine to shut down and then press and hold ON key for 3 seconds	Fill the hopper and perform steps to fill the auger and start the system
		Faulty pump		Contact service
		Faulty probe		Confirm the correct configuration of the heating system
Er05	Shut down due to high flue gas temperature	The flue gas temperature exceeds set limit	Allow the machine to shut down and then press and hold ON key for 3 seconds	Contact service
		Flue gas pipe is blocked		Check soiling of the flue gas pipe and its components
		Faulty flue gas pipe probe		Contact service
Er07	Encoder error	NO Encoder signal	Allow the machine to shut down and then press and hold ON key for 3 seconds	Contact service
Er08	Encoder error	Smoke discharge fan blocked	Allow the machine to shut down and then press and hold ON key for 3 seconds	Contact service
		Smoke discharge fan is working faster or slower than set		
Er09	Low water pressure	Low system pressure	Allow the machine to shut down and then press and hold ON key for 3 seconds	Check the water pressure level in the system
		Faulty probe		Contact service
Er10	High water pressure	High system pressure	Allow the machine to shut down and then press and hold ON key for 3 seconds	Check the water pressure level in the system
		Faulty probe		Contact service
Er11	Clock error	Problems with the internal clock	Press and hold ON key for 3 seconds	Check operation of time setting
		Insufficient charge of the internal battery		Check operation of Chrono mode
Er12	Extinguishing in case of power outage	Faulty ignition	Allow the machine to shut down and then press and hold ON key for 3 seconds	Contact service
		During ignition flue gases do not reach adequate temperature		Check soiling of the grate
		Faulty flue gas pipe probe		Check the condition and quality of used pellet
Er15	Extinguishing in case of power outage longer than 50 minutes	Power outage during operation	Press and hold ON key for 3 seconds	Check soiling and draft of flue gas pipes and chimney
				Contact service
Er17	Failure to adjust the air flow	The primary air flow meter is not adjusting the boiler operation	The machine continues to operate without primary air flow adjustment.	Check power supply
				Contact service
				Check the primary air openings for soiling
				Check soiling and draft of flue gas pipes and chimney
				Contact service

			To reactivate the sensor shut down the machine. Allow it to shut down and press ON key for 3 seconds	
Er39	The primary air flow meter sensor is damaged	Faulty sensor	The machine continues to operate without primary air adjustment	Contact service
Er41	Minimum air flow during check up not reached	An obstacle or major soiling of the primary air pipes	Allow the machine to shut down and then press and hold ON key for 3 seconds	Check the primary air openings
		Flue gas pipe is blocked		Contact service
		Inadequately closed door during the ignition phase		Check soiling and draft of flue gas pipe
				Contact service
Er42	Maximum airflow is exceeded	Excessive air inflow	Allow the machine to shut down and then press and hold ON key for 3 seconds	Check the primary air openings
				Check soiling and draft of flue gas pipe
				Contact service
ATTENTION: If the recommended solutions fail to remove the problem, contact the closest authorized service				

7. CONNECTION OF THE HYDRAULIC INSTALATION

In order to reduce the risk of condensation, it is recommended to use a three-way mixing valve with a fitting thermostat when installing the stove.

7.1 Scheme of the hydraulic installation of a pellet boiler (radiator heating)

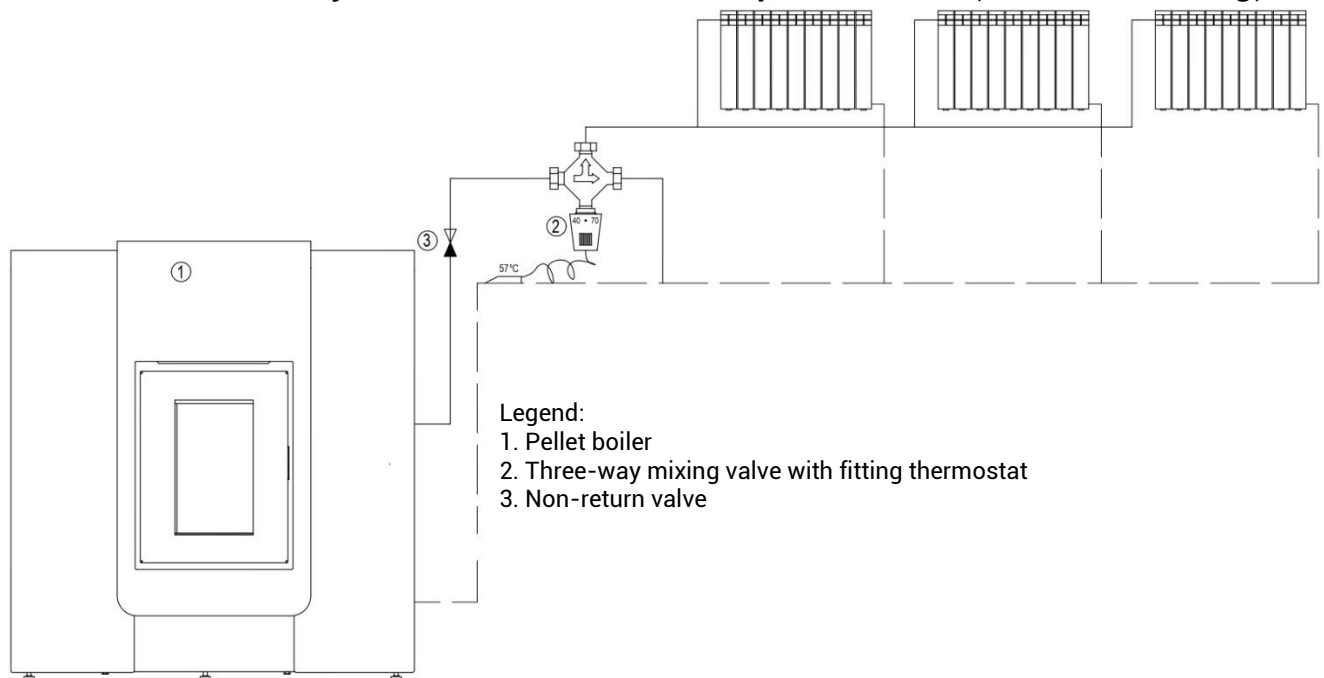

7.2 Scheme of the hydraulic installation of a pellet boiler (radiator and floor heating)

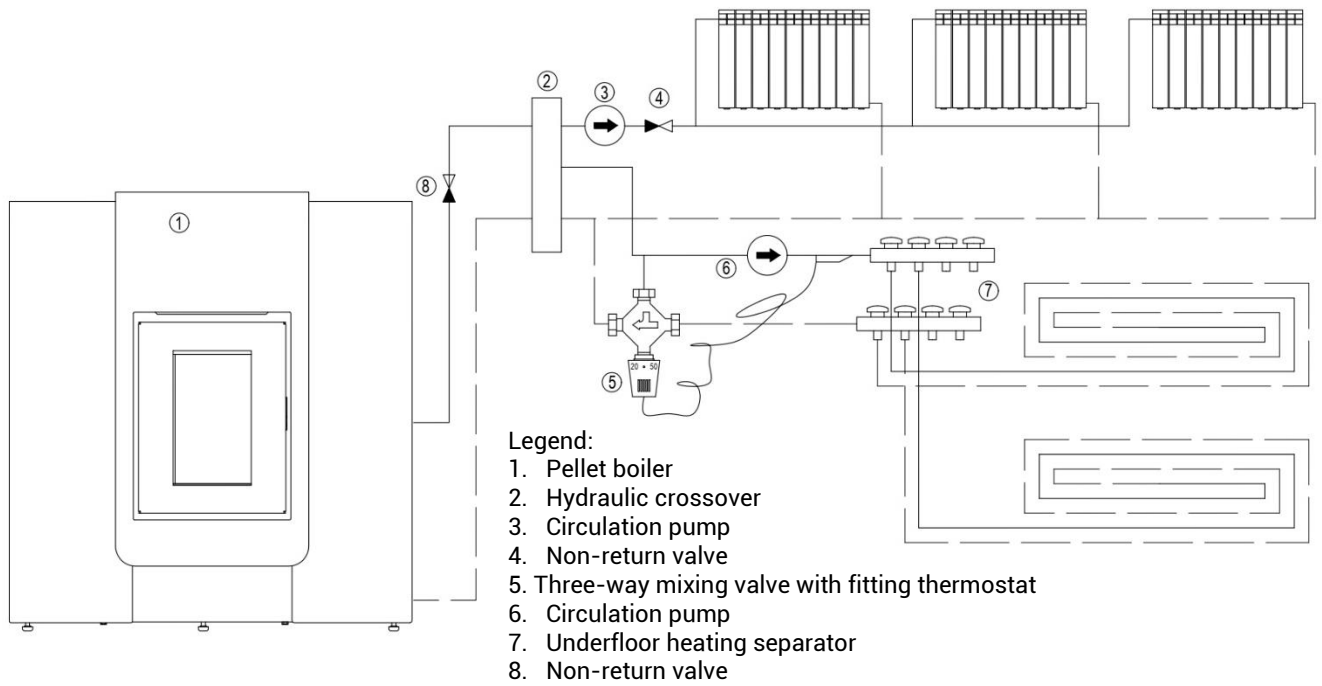

ALFA PLAM Company reserves the right to change this manual at any time and without previous announcement, in order to improve the quality of the product. ALFA PLAM is not responsible for any mistake or uncertainty in the content of this Manual. Any complete or partial reproduction of the Manual, without the Company's written approval is strictly forbidden. Offenders will be prosecuted. All data and measures are provided as indications.